

SCHÉMY NANÁŠANIA LEPIACEJ MALTY NA TEPELNOIZOLAČNÉ DOSKY

formát A4
mierka 1:12

detail
0.1

POHĽAD - ručne

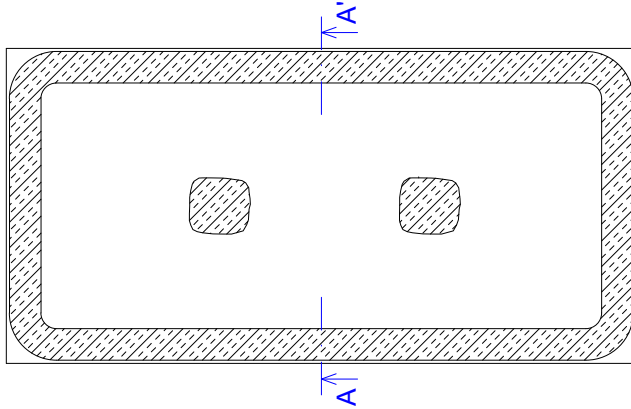

REZ A-A'

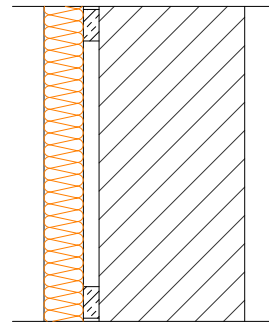

POHĽAD - ručne

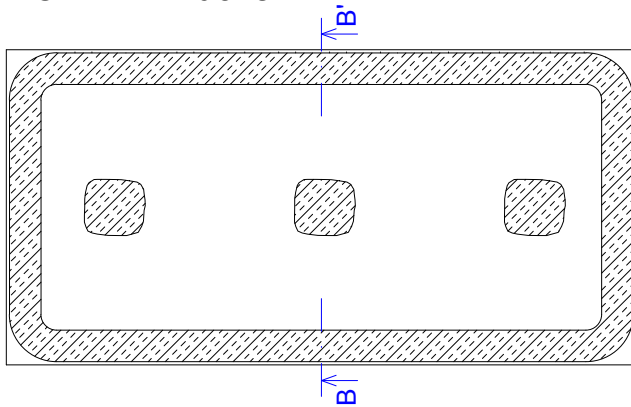

REZ B-B'

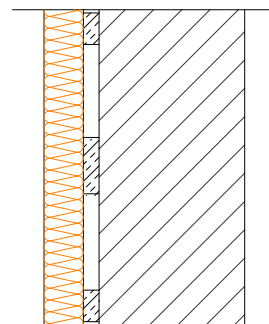

POHĽAD - strojne

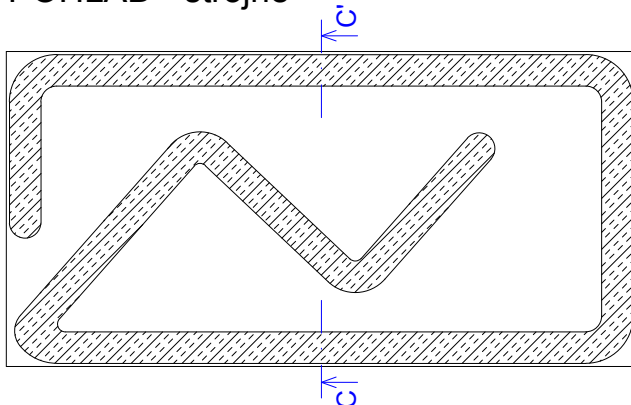

REZ C-C'

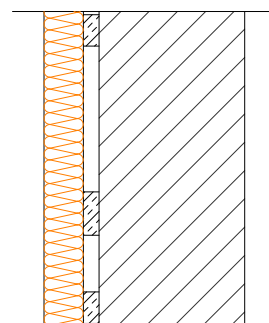

NEPLATÍ PRE LAMELY Z MINERÁLNEJ VLNY (KOLMO ORIENTOvané VLÁKNO)